

MASSMAN ENGINEERING, LLC.

FILTER-TECH DIVISION

STREAMLINING PRODUCTION THROUGH AUTOMATION

Automated Cartridge Assembly Machine
 ACAM Series H – Hot Melt Adhesive
 ACAM Series U – Ultrasonic Weld

We are experts at designing systems that help you increase production efficiency, improve production flexibility plus reduce manufacturing costs.

1. Filter Collation

Positions pleated block

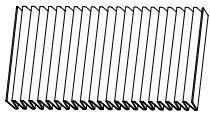

2. Filter Forming

Forms into cylinder

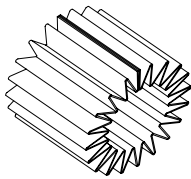

3. Filter Joint Securing

Secures joint with Hot Melt or Ultra Sonic Weld

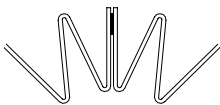

4. Center Tube Assembly

Inserts tube in pleat block

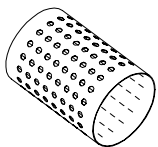

5. Assembled Cartridge



Hot Melt Extruder

Hot Melt or Ultra Sonic Weld –
 Saves cost and increases production

ACAM Series - H

- Used in many manufacturing applications
- Compression section sets adhesive quickly
- Precise registration of adhesive joint



ACAM Series - U

- Cuts material costs
- Used in a variety of filter applications
- Environmentally safe
- Clean manufacturing process



U.S. Patent No. 6,230,777
 U.S. Patent No. 6,616,785
 U.S. Patent No. 6,615,893

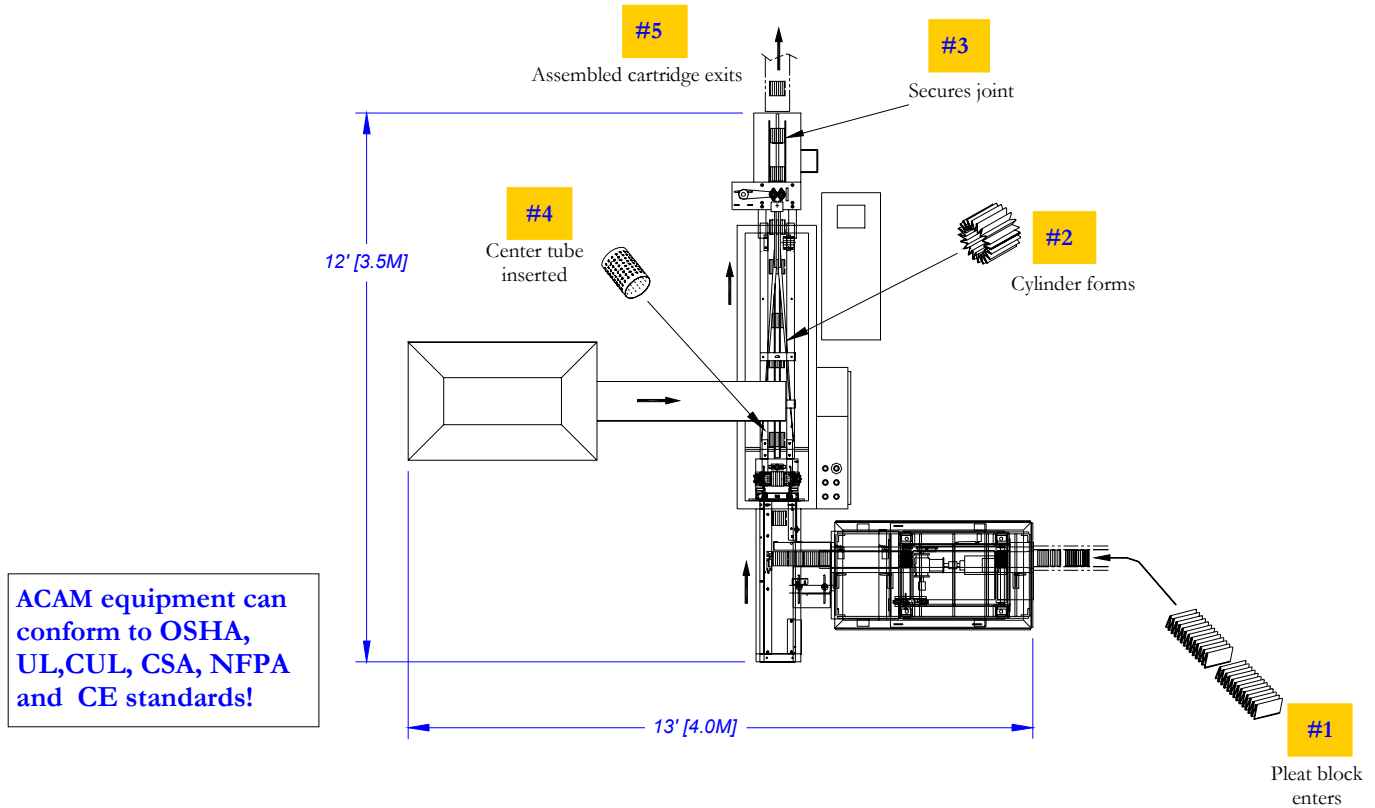

Product Specifications

Model	400H	600H	1200H
Type of Seam	Hot Melt	Hot Melt	Hot Melt
Through-put rate	60/min	60/min	45/min
Slit Width Range	1.25 – 4.00 inch 30-100 mm	1.60-6.00 inch 40-150 mm	2.0 – 12.0 inch 50-300 mm
Pleat Depth Range	0.375 – 0.750 inch 10-20 mm	0.500 – 1.000 inch 12 – 25 mm	0.500 – 1.500 inch 12-38 mm
Center Tube Diameter Range**	1.0 – 1.3 inch 25 –32 mm	1.2 – 2.0 inch 30-50 mm	1.2 – 2.8 inch 30-70 mm

** Center Tube feeding and Assembly is available on all models as an option

For more information, please contact:



651-739-1700 • fax 651-739-1777 • 7033 6th St. N. • St. Paul, MN 55128 USA
www.MassmanLLC.com • info@MassmanLLC.com